

Automating the Payment of Toll Tax at Toll Plazas

Kruti Sanghvi , Prof.Amol Joglekar

Mithibai College, Mumbai

Abstract: The major problem being heavy traffic at every Toll Booths in the city can be practically reduced by the introduction of the Radio Frequency Identification Based Toll Tax Automation System which makes the Toll Deduction at the Toll Plaza's more efficient and perfect. Its primary requirement is to wipe out the need for automobilist and toll authorities to manually perform toll gateway payments and toll tax collections, respectively in order to go past the toll booth. The proposed RFID system transmits a particular ID code as soon as it reaches near the toll station. On receiving the code, processor checks the received code and compares it with the stored code, if the code matches the gates open else they remain closed disallowing the vehicle to pass. This paper focuses on use of radio frequency identification (RFID) technology for electronic toll collection system. Due to which the problem of traffic congestion and human errors in the system is effectively rectified and provides efficient toll tax collection facility for the consumers at every Toll Station.

Keywords: Toll Tax, Toll Booths, Automation, RFID, Sensor.

I. INTRODUCTION

Everyday thousands of people go past the toll tax booth paying toll tax. Currently the toll payment system is manual; the drivers are made to use a manual system by which payment is done by cash by hand method to pass across the toll plaza gate. Manual process is very time consuming, the drivers have to wait in row for long time for crossing the toll plaza. During their wait, time and fuel of vehicle is highly consumed. With the introduction of Automatic Toll Tax System the problem of unnecessary fuel consumption will be drastically reduced. Where drivers will not have to wait for cash payment or get a token to cross the toll plaza. Hence we propose a new automatic system using RFID technology. It is an advanced technique which allows electronic payment for vehicles which passes through a toll booth. An Automatic Toll Collection system is able to determine if a car is registered in a toll payment program, by comparing the unique code given to each car that is stuck to the windshield of the car, with the database stored in the processor in order to authenticate the incoming car. After the cars are authenticated and they match the unique ID stored in the database, the respective toll amount gets deducted from their bank accounts following which the gate automatically opens and the cars are allowed to pass else they are not allowed. Electronic toll collection should be made a globally accepted method of toll collection, a trend greatly aided by the advancement in the field of interoperable Electronic Toll Collection technologies. The most noticeable advantage of this technology is the opportunity to wipe out congestion in tollbooths, especially during festive seasons when traffic tends to be heavier than normal. It is also a method that helps curb complaints from automobilists regarding the inconveniences involved in manually making payments at the tollbooths and the errors

that get generated. Other than this obvious advantage, applying ETC could also benefit the toll operators. Frequency Identification (RFID) is an automatic identification technology which uses Radio Frequencies to identify objects remotely. The system does the job of detecting and accounting for vehicles as they pass through a tollgate using RFID as the identification technology. The system is a great asset in the transport industry. It reduces the common problems in accounting for the transportation of goods from point to point. This can be the approach that focuses on how radio frequency identification technology can be used to solve problems faced by public at the toll booths in metro cities. There are, however, disturbing obstacles in the way of widely spread radio frequency identification network deployment. From the proposed systems point of view, this highlights and wipes out the problem of data capturing, storage and retrieval and how event, condition and action rules developed for active databases can help us in managing the huge number of events generated each day at every toll booth in the city. It also highlights how the collected data can be used to complete the toll tax money transfer from the bank account of the person in order to provide better customer service. The primary focus of this concept is the use of RFID technology to solve problems faced by passengers in many cities.

II. BACKGROUND AND RELATED WORK

R. M. Hushangabade, S.V. Dhopte[1] proposed that the system is a great asset in the transport industry. It reduces the common problems in accounting for the transportation of goods from point to point. The RFID Automatic tollgate system designed could automatically detect the identities of the vehicles and performed the billing in accordance to the identity of each vehicle as prerecorded in the database. The system could automatically inform the owners of the vehicles. These were the major achievements met in the paper, among other objectives also achieved which include tracking of the vehicles and remote database connection. S.Nandhini1, P.Premkumar[2] proposed that proposed of the automatic toll tax payment system and the amount transaction information sends to the cell phone of the motorists through the GSM modem technology. It is an innovative technology for expressway network automatic toll collection solution. In this paper, the frame composing and working flow of the system is described and data information is also easily exchanged between the motorists and toll authorities, thereby enabling a more efficient toll collection by reducing traffic and eliminating possible human errors. Cao QuocHuy[3] focused on a Line follower robot is a mobile machine that can detect and follow line which is drawn on the floor.

Siuli Roy, Somprakash Bandyopadhyay, Munmun Das, Suvadip Batabyal, Sankhadeep Pal[4] proposed to design a smart and fully automatic system that will detect the congestion in real time, and subsequently manage it efficiently to ensure smooth traffic flow with the use of Active RFID devices.

Khalid Al-Khateeb, Jaiz A. Y. Johari proposed that RFID traffic control avoids problems that usually arise with standard traffic control systems, especially those related to image processing and beam interruption techniques.

Rshreffler [6] proposed that ETC is a system that aims to eliminate the delay on toll roads by collecting tolls electronically. Automated vehicle classification is closely related to automated vehicle identification. Most toll facilities charge different rates for different types of vehicles, making it necessary to distinguish the vehicles passing through the toll facility.

III. RESEARCH METHODOLOGY

A. Proposed System:

In this proposed paper, what I have tried to put forward is the radio frequency identification toll system based on Radio Frequency Identification Technology. It can achieve the collection of charges without stopping the vehicle running in high speed for a very long time. Also

authentication of the vehicle can be done by browsing the data stored in the central database and comparing it with the unique ID given to each vehicle. The concrete operations are as follows: It is required to install hardware equipment at each highway toll station, namely, reader, controller, data transmission unit, remote non-contact charging machines, bank payment gateway and other facilities in the control room of toll station, installing structure for mounting of reader mechanism and installing alarms and other devices to realize automatically that the tag is passed in the region of the magnetic field produced by the RFID module and a beep sound is produced signaling its detection. The RFID module needs to be configured with certain communication parameters. This can be done using the given Specific instructions and can be achieved by using the Dummy Prototype Application or an independent developed application. Each vehicle will be provided with an RFID tag containing a unique ID. This tag will continuously emit RF signals. When the vehicle will reach at the toll booth the RF receiver will detect these RF signals. The signals are amplified and are passed to microcontroller. This microcontroller will display the id on a displaying device which will be provided in toll-station

B. Block Diagram

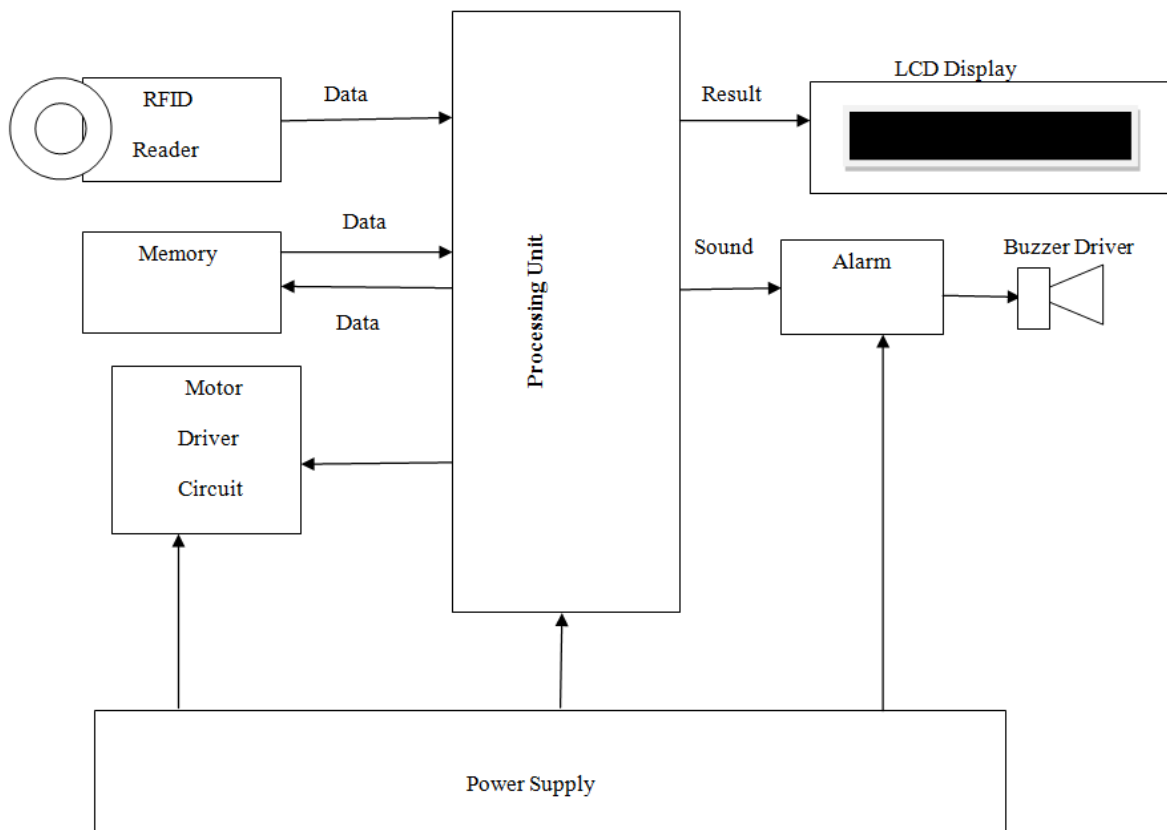

Basic Block Diagram of Automatic Toll Tax System

Flow of System:-

- ✓ Vehicle comes to a toll plaza.
- ✓ System will check the details of vehicle.
- ✓ There will be an automatic payment made by the system with the registered details.

When the vehicle is going to enter into the toll plaza, the first aim is to validate the vehicle for its authenticity. For that purpose it has to first pass through the IR Transmitter -

Receiver gate. Then we have here the RFID system. The system will automatically detect a tag which is stuck to the front glass of the vehicle the (windshield). This gathered data will be compared with a database stored in the system. If the data is matched with the stored data automatically system will act and takes money from his registered account. This is the simple concept explained in this paper.

C. Proposed Algorithm:

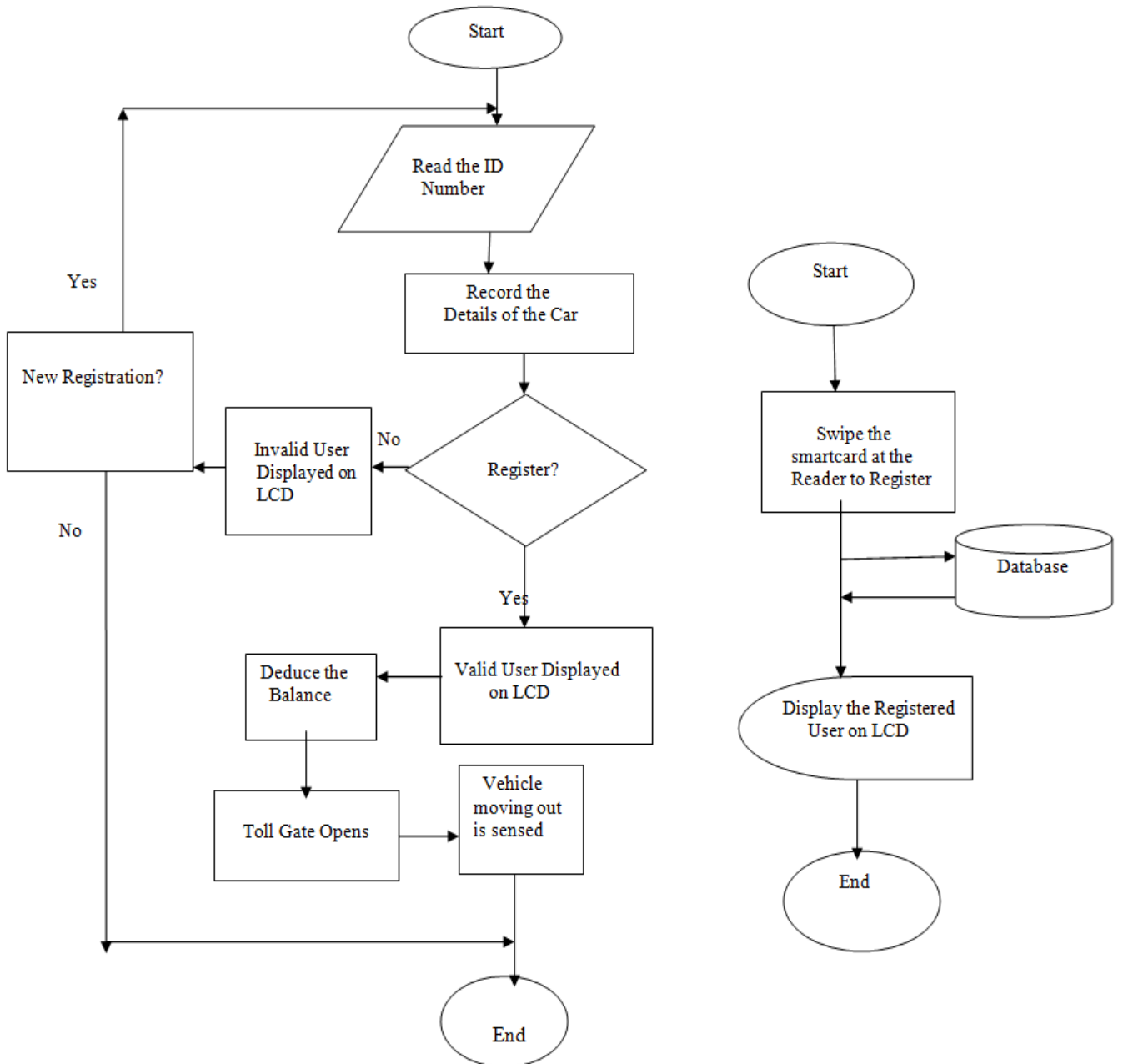

Overall flow chart for toll collection system and User registration flow chart

IV. FUTURE ENHANCEMENT:

Vehicle number plate recognition and Aadhar card Linked with Vehicle Number and driving license :

A vehicle's number/license plate recognition algorithm is based on the very elementary technique of Templates matching. The algorithm takes an input image of the number plate (number plate should be dominant in the image) and after filtering the image, it performs region based operations. Then it tries to capture the characters regions in a processed binary image and with the aid of template matching outputs the string of number plate characters. The primary aim of this Direct Benefit Transfer program is to bring transparency and terminate pilferage from distribution of funds sponsored by Central Government of India. In DBT, benefit or subsidy will be directly transferred to citizens living below poverty line. Central Plan Scheme Monitoring System (CPSMS), being implemented by the Office of Controller General of Accounts, will act as the common platform for routing DBT. CPSMS can be used for the preparation of beneficiary list, digitally signing the same and processing of payments in the bank accounts of the beneficiary using the Aadhaar Payment Bridge of NPCI.[2] All relevant orders related with the DBT are available on the CPSMS website. While aadhaar card is mandatory for registering new vehicle and obtaining driving licence.it is also expected to help AP Transport Department for better operations and also Security of Vehicle their owners. The concept is to link the consumer's Aadhar card number with their vehicle details and driving license. The person who are planning to register their vehicle for driving license will now have to provide Aadhar card details at the respect Regional Transport Offices

Flexibility of implementation:

The main power of ATTS (Automatic Toll Tax System) is the technology which is used, that is the Radio Frequency based Technology. The basic power of this technology is that it's very flexible. Even with the slightest of change in ATTS, the product can be shaped into a completely different implementation and all that can be because RFID is independent of every other hardware that can be used to boost up the system's performance Radio Frequency.has vast implementation areas in medical, defense and many latest products that are being developed is based on RFID solution. The main areas is animal tracking, human Implants, vehicle tracking, speed tracking, physical implementation.

V. CONCLUSION

This paper focuses on the usage of RFID technology as it offers reliable data collection. The proposed system will be an automated model which will give a guarantee on collected funds will have some transparency. As the system is developed with the help of some high end applications which provides easy and fast processing.

REFERENCES

1. Jalan Kajang-Puchong and Kajang, Selangor, "Analysis of Line Sensor Configuration for the Advanced Line", Department of Electrical Engineering, Department of Mechanical Engineering, University Telangna National, Km7, 43009, Malaysia.
2. <https://rshreffler.wordpress.com/tag/electronic-toll-collection/>.
3. M. Hushangabade, S.V. Dhopte, "Dynamic Approach towards Toll Tax Collection and Vehicle Tracking With the Help of RFID", International Journal of Engineering and Innovative Technology (IJEIT), Volume 3, Issue 1, July 2013.
4. S.Nandhini1, P.Premkumar2," Automatic Toll Gate System Using Advanced RFID and GSM Technology", International Journal of Advanced Research in Electrical, Electronics and Instrumentation Engineering (An ISO 3297: 2007 Certified Organization) Vol. 3, Issue 11, November 2014.
5. Priyanka Sharma and Vivek Sharma, "Electronic toll collection technologies: A state of art review", International Journal of Advanced Research in Computer Science and Software Engineering, Volume 4, Issue 7, July 2014.
6. Gokhale ES's R.H. Sapat, "Automated Toll Collection System Using RFID", (Computer Engineering, COE MSR, Nashik-05/ Pune University, India).
7. Pkhadija KamarulaziziI, PPDR.Widad Ismail, "Electronic Toll Collection system using passive RFID technology", Journal of Theoretical and Applied Information Technology © 2005 - 2010 JATIT & LLS.
8. Shilpa Mahajan," Microcontroller Based Automatic Toll Collection System", International Journal of Information and Computation Technology ISSN 0974-2239 Volume 3, Number 8 (2013), pp. 793-800.
9. Shobit Shanker,Syed Masud Mahmud, "An Intelligent Architecture for intelligent area parking and toll collection", (IEEE 2005).
10. Raadhikaa,"Electronic Toll Collection System", UNIASCIT, Vol 1 (1), 2011, 05-08
11. Ohba,H.Ueno,M.Kuwahara, "Travel Time Information Calculation Method for Expressway using Toll Collection System Data", 6th World Congress on Intelligent Transport Systems, Nov.1999.
12. JT.Kurosawa,K.Ogawa, "A Study on Travel Time Prediction Method on Inter-City Expressways Using Traffic Capacity at The Bottleneck", 5th World Congress on Intelligent Transport Systems,Oct.1998.
13. Sudha Bhalekar, Adesh Chanageri G., Indra Prakash Chauhan," Automatic Toll Tax Using RFID", International Journal of Computer Technology and Electronics Engineering (IJCTEE) Volume 3, Special Issue, March-April 2013.